

**KINGDOM OF MOROCCO
ROYAL ARMED FORCES
GENERAL HEADQUARTERS**



**« AFRICAN LION » JOINT EXERCISE
PRESENTATION**



"African Lion" Exercise is considered as one of the most important joint multinational exercises conducted within African continent.

PLAN



■ History;



■ Current dimension ;



■ Feedback, objectives and perspectives.



PLAN

- History of African Lion exercise;





African Lion Exercise was initiated since 2004





Simulation Exercise CPX





CO Architecture Of the 1st CPX

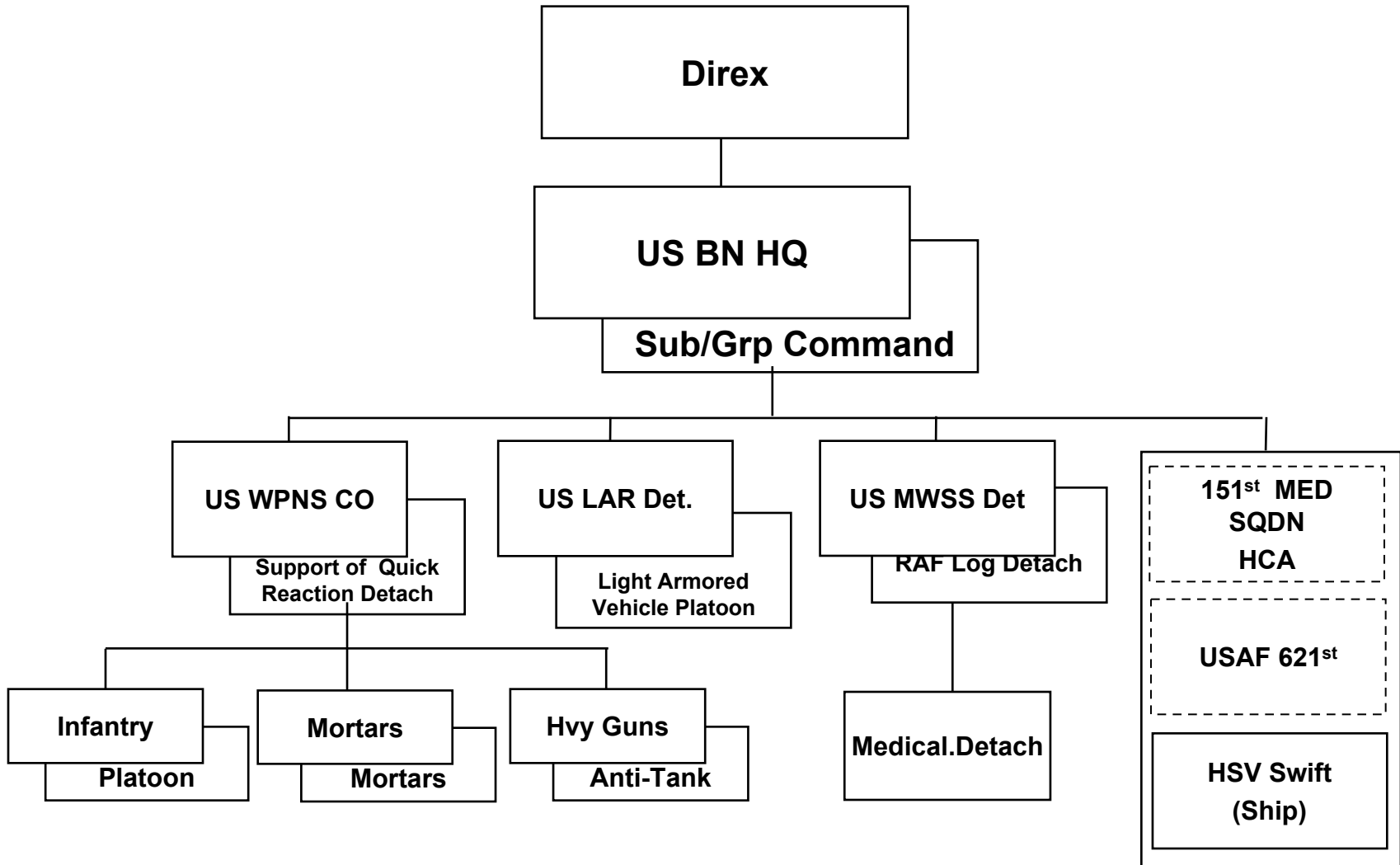

Task Organization / Command Relationships

Legend

- COCOM
- OPCON
- - - TACON
- DIRECT SUPPORT
-> SUPPORTING
- . - . DIRLAUTH/
- Coordinating

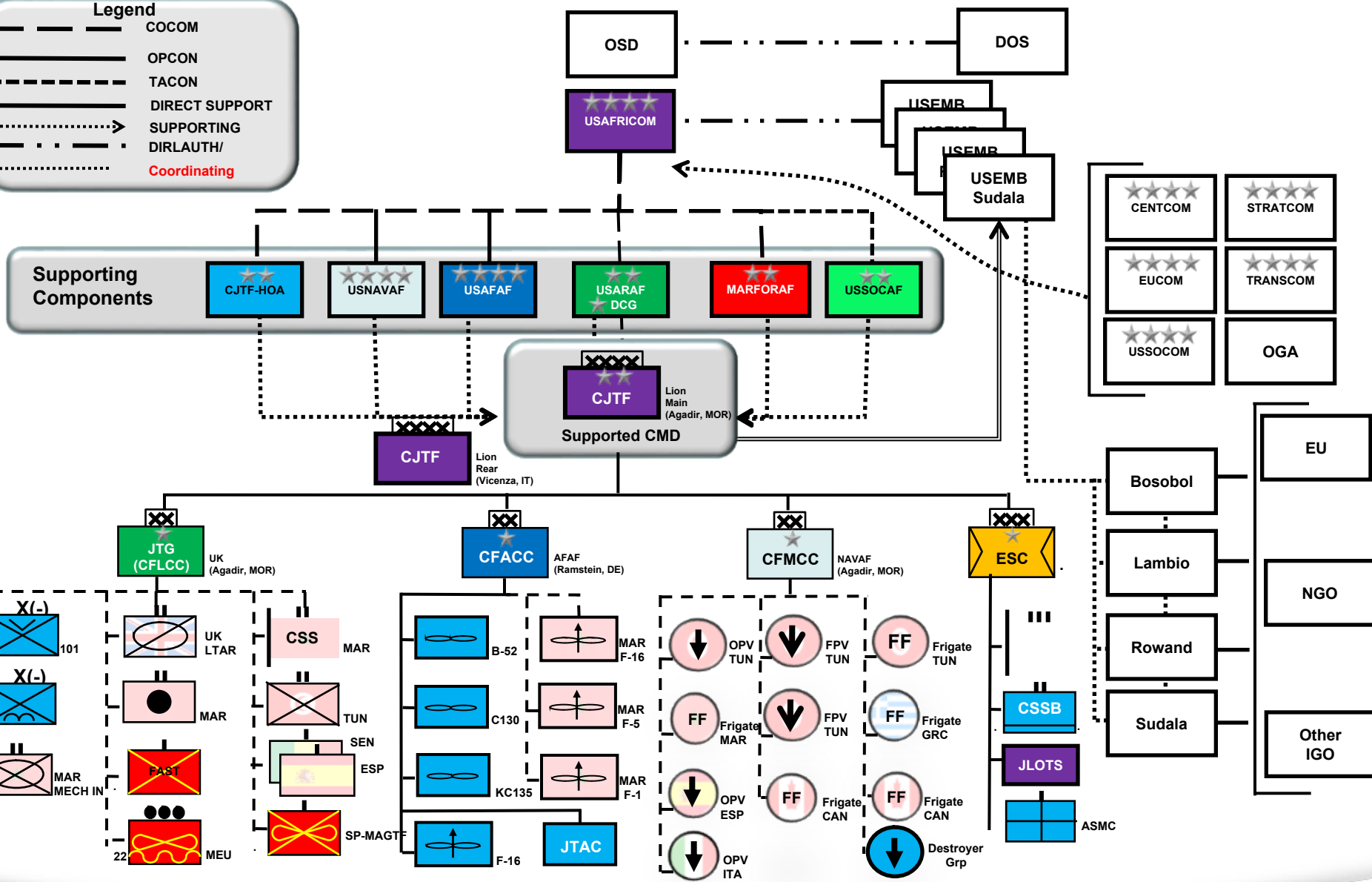

Component Operating Locations

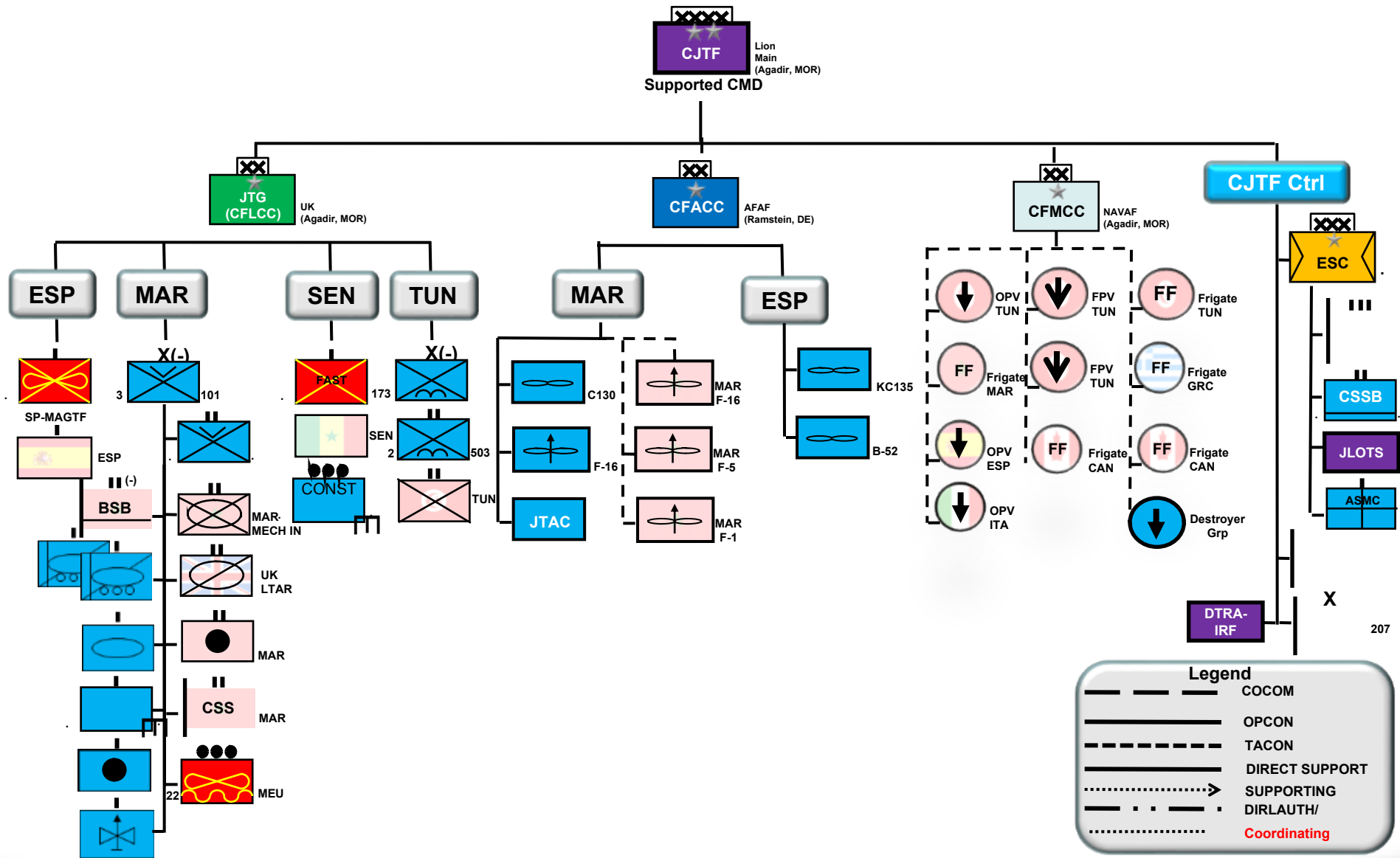



The Year 2010



the integration of command elements of the Task Force and a Regimental Headquarters for the simulation exercise.





The Year 2010



Exercises on Peace Support Operations



Air component





Navy Component





Navy Component



The year 2015

HIGH LEVEL SEMINAR « HLS »



The Year 2018



ACTIVITIES	RAF PARTICIPATION	U.S AND MULTINATIONAL PARTICIPATION	TOTAL
C.J.T.F	40	5	45
FTX	650	230	880
CPX	39	160	199
C-VEO	150	106	256
ACADEMICS	100	18	118
CIMIC	119	90	209
ATX	157	550	712
EXERCICE SIMULE DE DECONTAMINATION RNBC	45	5	50
TOTAL	1300	1164	2464

SCHEDULED ACTIVITIES

- **Tactical combined exercise with live fire at CAPDRA;**
- **Simulation exercise;**
- **Exercise on Peace Support Operations;**
- **Multinational amphibious assault exercise at CAPDRA;**
- **Tactical training of Royal Air Force and American pilots;**
- **Medico-dental services in the region of Tata;**
- **High level seminar on cross-border threats.**



15 countries representing Africa, Europe and North America



PLAN



■ **current dimension of the African Lion exercise**

The Year 2021



ACTIVITIES	RAF PARTICIPATION	U.S AND MULTINATIONAL PARTICIPATION	TOTAL
FTX	1233	914	2147
CPX	120	617	737
ATX	200	237	437
Animal Health and Water Safety Exercise	08	11	19
Special Forces Exercise	86	174	260
Airborne Exercise	218	525	743
MEDREX	15	17	32
ACADEMICS	100	18	118
CIMIC	130	75	205
CBRN Simulated Decontamination Exercise	45	28	73
TOTAL	2155	2616	4771

PLANNED ACTIVITIES



- Combined tactical exercise with live fire at CAPDRA;
- Simulation exercise;
- Special Forces Exercise;
- Airborne Exercise at Grier Labouhi;
- Multinational Amphibious Assault Exercise at CAPDRA;
- Tactical training of FRA and American pilots;
- Medical-dental benefits in the Tafrouat region;
- Animal Health and Water Safety Exercise;
- CBRN Simulated Decontamination Exercise.



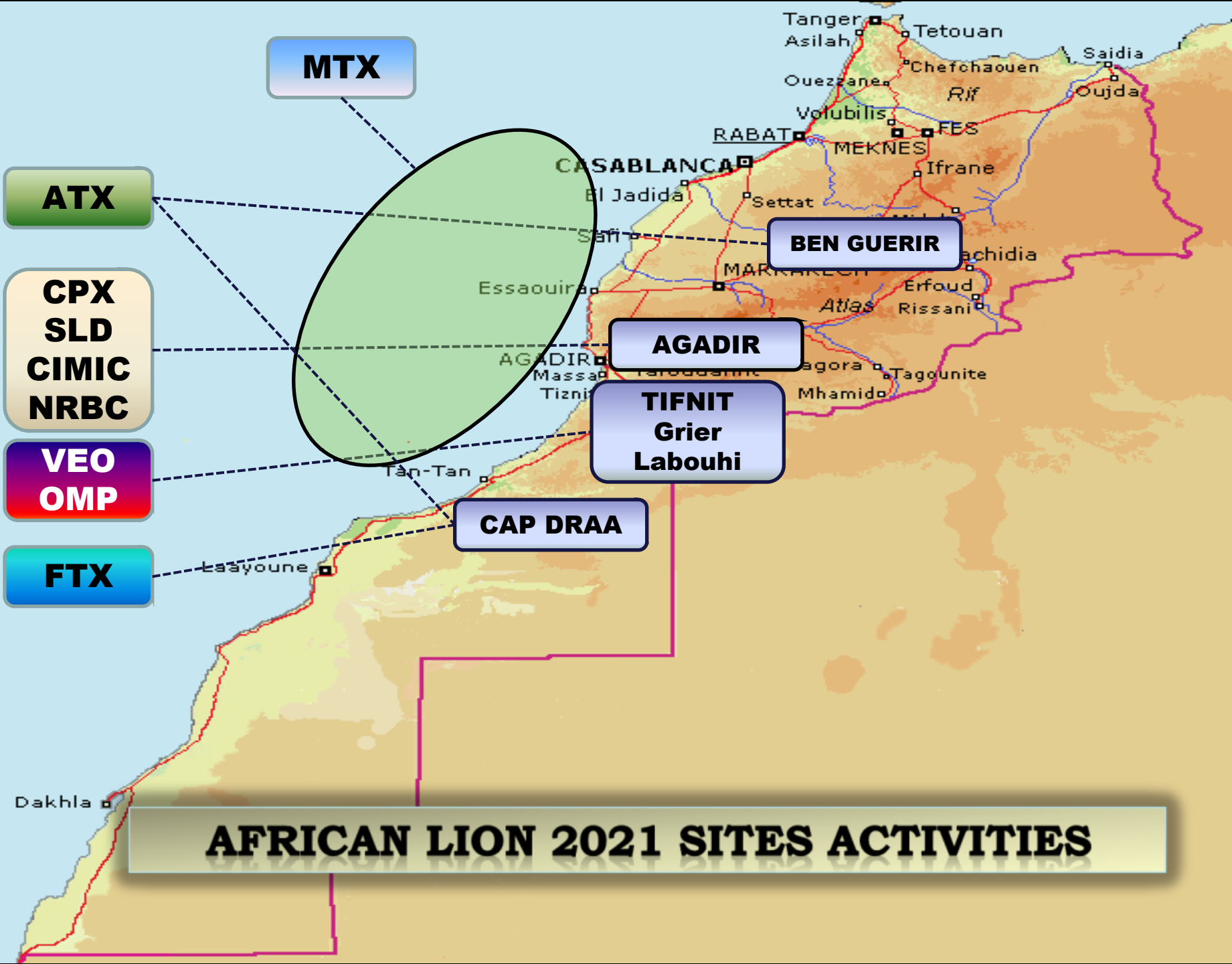

MTX

ATX

**CPX
SLD
CIMIC
NRBC**

**VEO
OMP**

FTX

BEN GUERIR

AGADIR

**TIFNIT
Grier
Labouhi**

CAP DRAA

AFRICAN LION 2021 SITES ACTIVITIES

PLAN

- Objectives and outlook for the year African Lion.





OBJECTIVES

- Enhance the operational readiness of the various components and promote interoperability in terms of tactics, technics and procedures;**
- Plan and conduct combined air and maritime air missions as well as maritime interdiction operations;**
- Reinforce the manoeuvrability of the forces to operate in an austere environment with real fire execution in tactical environment;**
- Organize joint training in the fight against violent extremist organizations;**
- Conduct joint civil-military actions and exchange of expertise in the field of medical support in operations.**

AFRICAN LION OBJECTIVES 2022



JOINT OBJECTIVES

- 
- Strengthen the skills of FAR officers in mastering the operational planning process ;
 - Familiarize yourself with the conduct of a conventional joint operation with the implementation of a Force CP (CJTF);

- 
- Understand the strategic and tactical contingencies of an operation as part of a multinational engagement;
 - Mastering the joint targeting process;

- 
- Develop technical and procedural interoperability between RBF components and partner country forces;
 - Plan and conduct a CSAR (Combat Search and Rescue) operation;

AFRICAN LION OBJECTIVES 2022



ARMY OBJECTIVES

- 
- Staff techniques training within an Area (OC);
 - Military Training on Combat Procedures (SOP and TTP;.....)
 - Helicopter Mission Integration and Conduct;

- 
- CBRN Decontamination Exercise;
 - Training Counter Violent and Extremist Organizations (C-VEO);
 - Planning and execution of the hostage release mission;

- 
- FAR/JTAC Advanced Air Controller Training;
 - Cyber Defense Training;
 - Tactical Data Link (TDL) Planning Training;



AFRICAN LION OBJECTIVES 2022

ARMY OBJECTIVES

- 
- C2 (CO) training with using a new systems;
 - Conduct of simulation exercises (JTLS / JCATS);
 - Civilian-Military Presentations (CIMIC).



AFRICAN LION OBJECTIVES 2022

ROYAL AIR FORCE OBJECTIVES

- Consolidate the achievements of previous editions of Exercise African Lion in terms of interoperability, SOP and TTP;
- Conduct combined air-to-air and air-to-ground training;
- Conduct combined arms electronic warfare missions;
- Training Defense Controllers of Royal Air Force Air .



AFRICAN LION OBJECTIVES 2022

ROYAL AIR FORCE OBJECTIVES

- **AAR qualification and training (day and night);**
- **Combined arms training to BVR tactics;**
- **Air-Ground/CAS Offensive Mission Training;**
- **SEAD mission simulators against US threats;**
- **LFE (Large Force Employment) missions;**
- **Tactical Air Combat Training;**
- **SAR / MEDEVAC;**
- **Tactical Helicopter Support Missions;**
- **Support and transport missions.**

AFRICAN LION OBJECTIVES 2022



ROYAL NAVY OBJECTIVES

**Development of coordination within a maritime working group;
Conduct tactical evolutionary exercises;**

Planning and conducting naval operations from a COM Maritime Operations Centre;

Conduct of Maritime Anti-aircraft Warfare (AAW), Anti-submarine Warfare (ASW), Anti-surface Warfare (ASUW) operations (procedures);

**Bombardment fire at sea and on land;
SEAL Maritime Deployment;
Actual replenishment at sea;**

**Use of link-11;
Maritime Interdiction Operations (MIO);
Rescue at sea.**





THANK YOU FOR YOUR ATTENTION





QUESTIONS?

