

## System context diagram

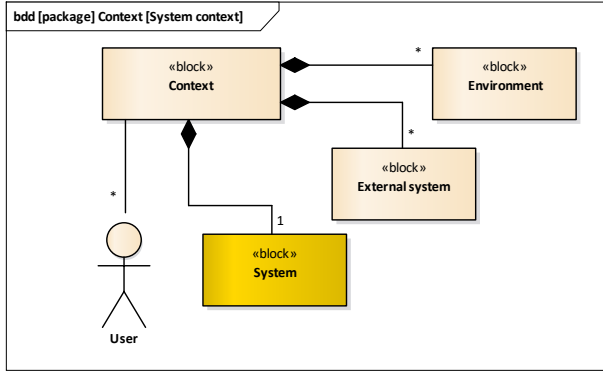

## Use case diagram

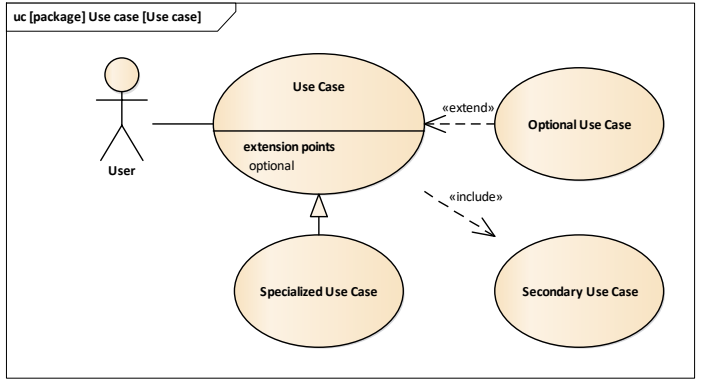

## Block definition diagram

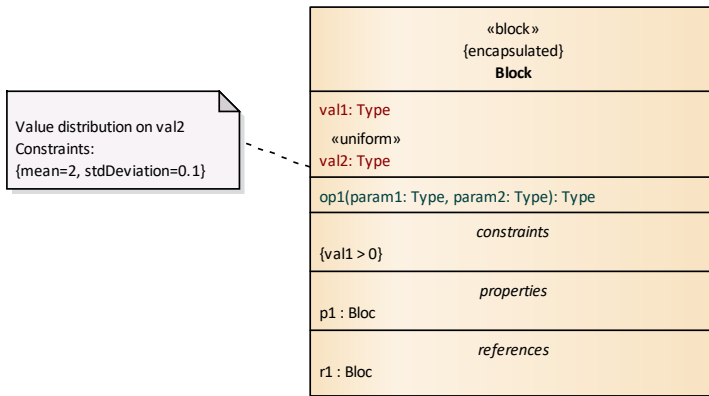

## Ports

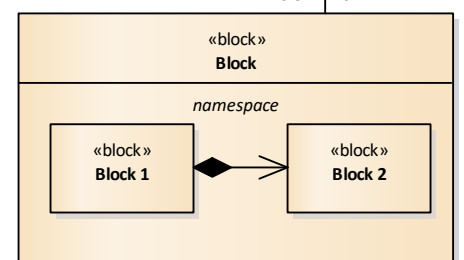
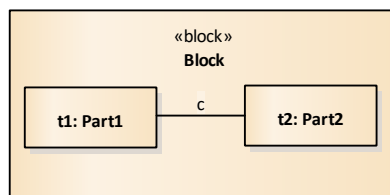
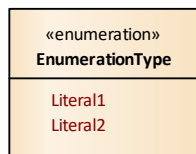
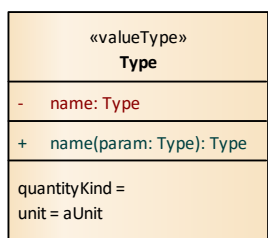
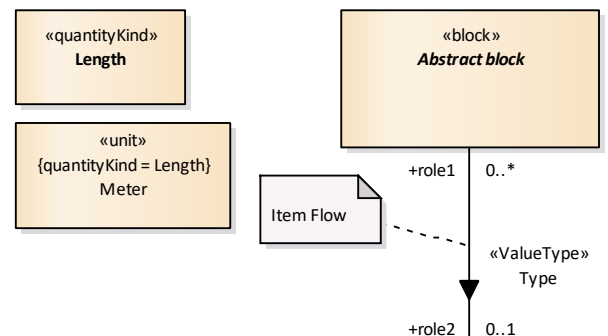
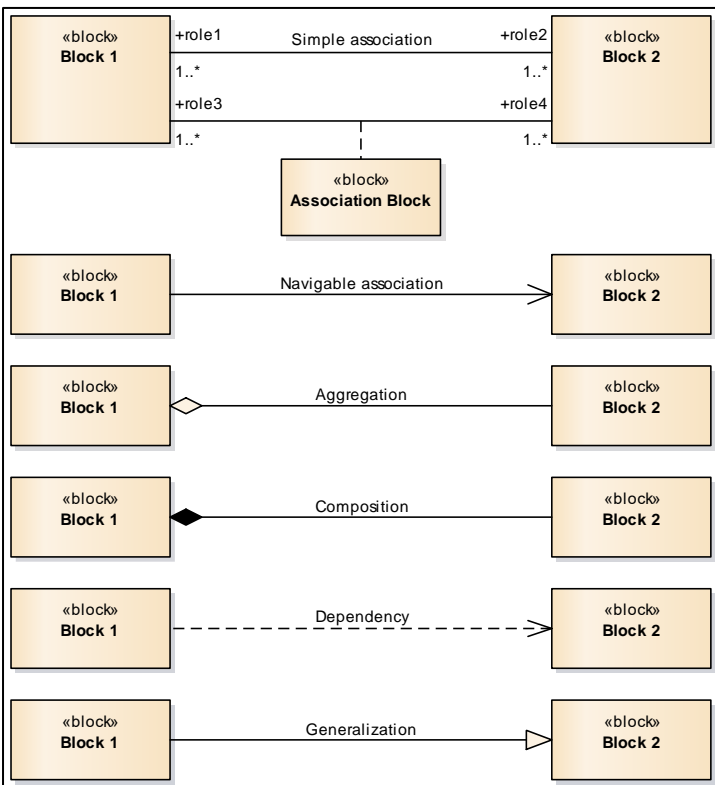
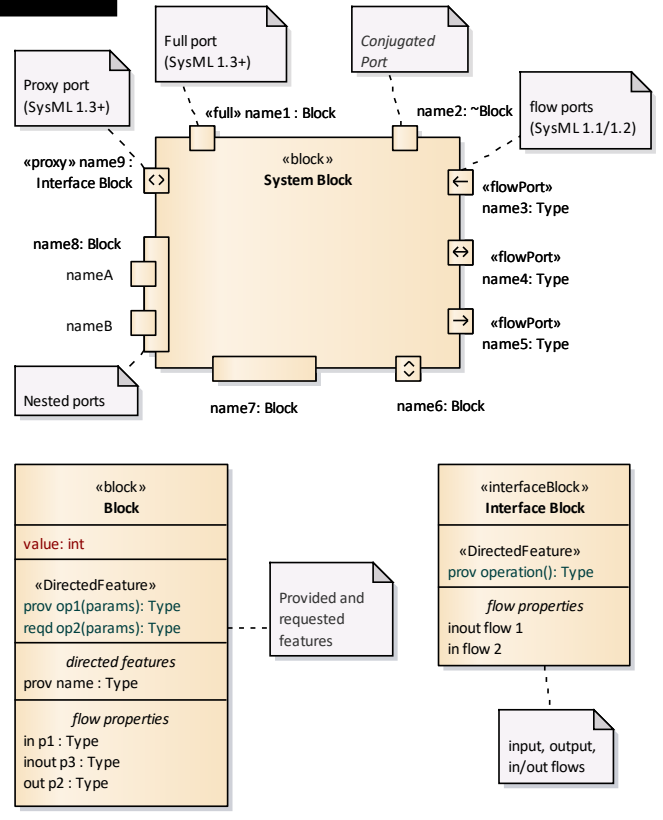

## Internal block diagram

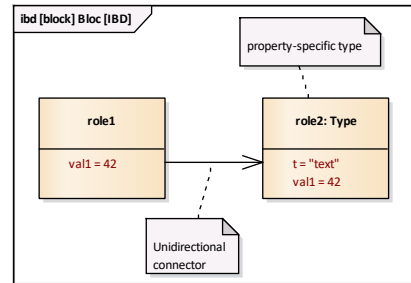
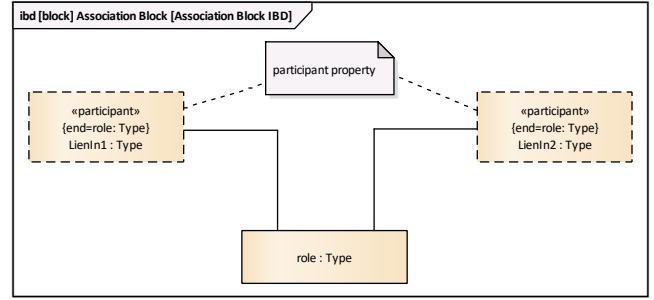
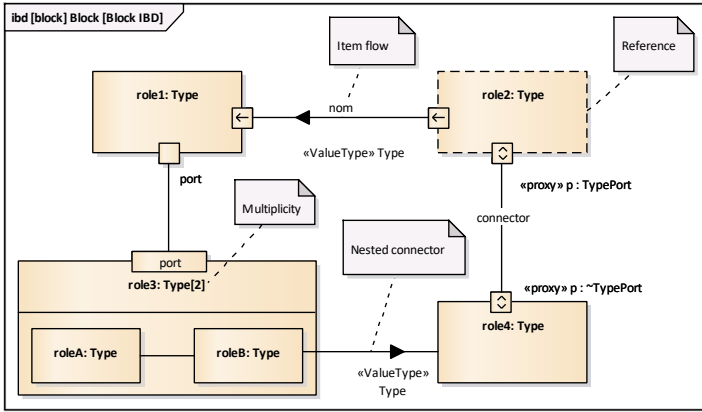

## Requirements

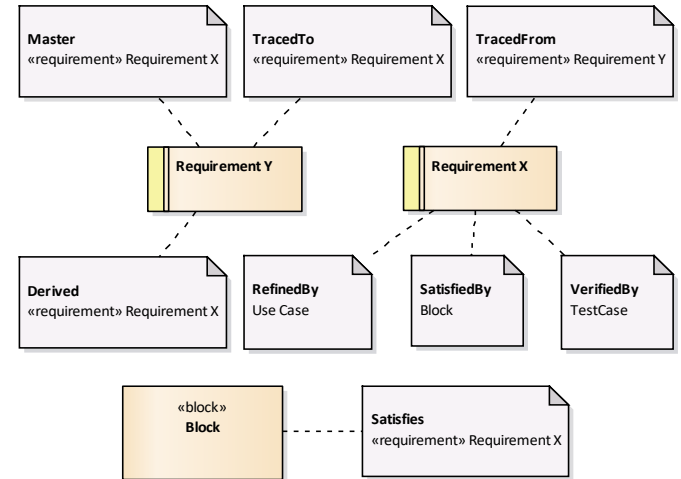
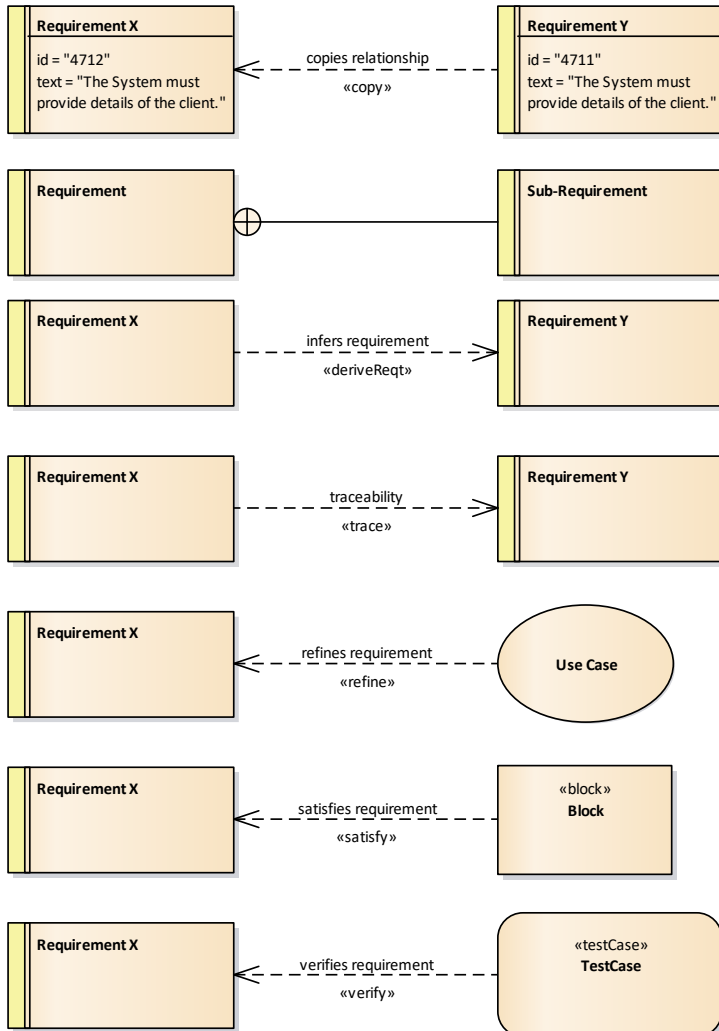

## Packages

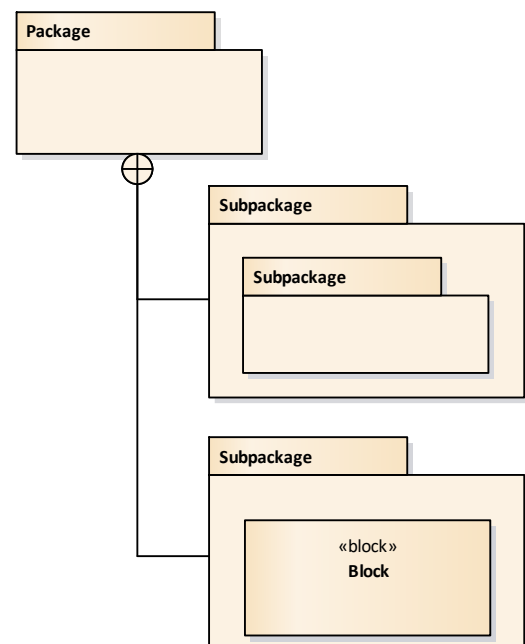

## Sequence diagram

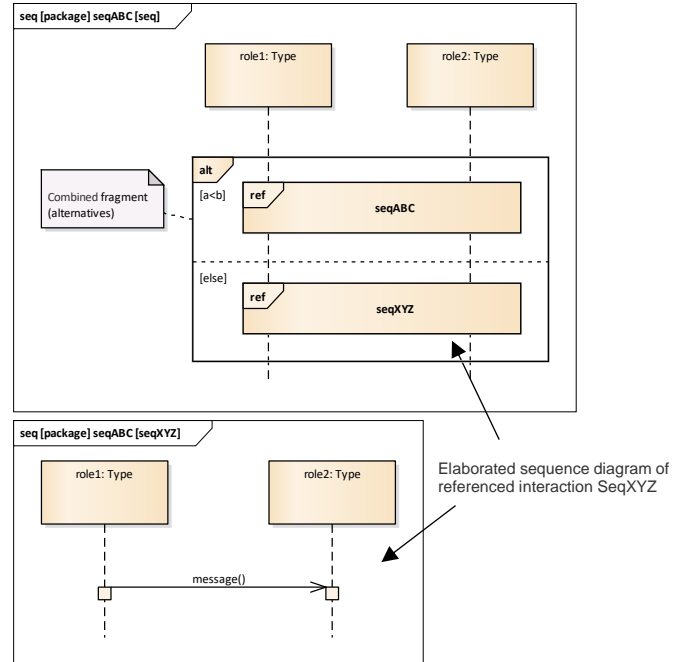
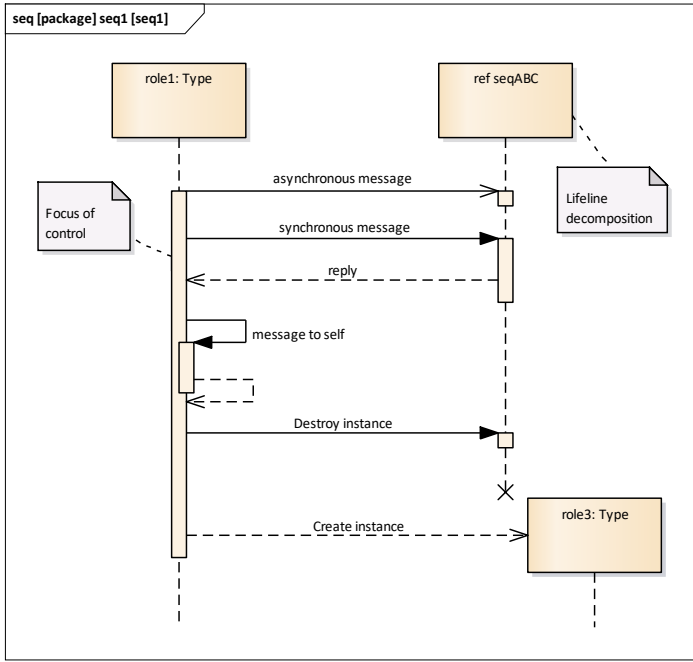

## Activity diagram

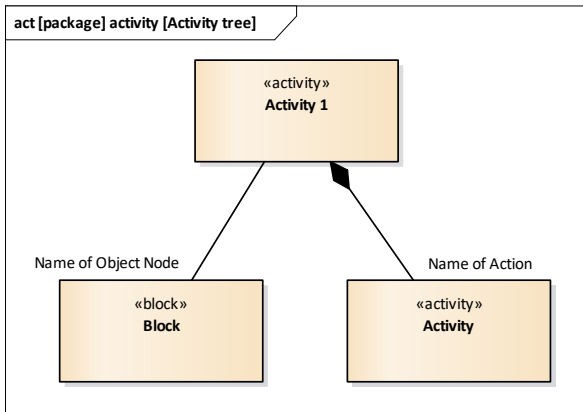
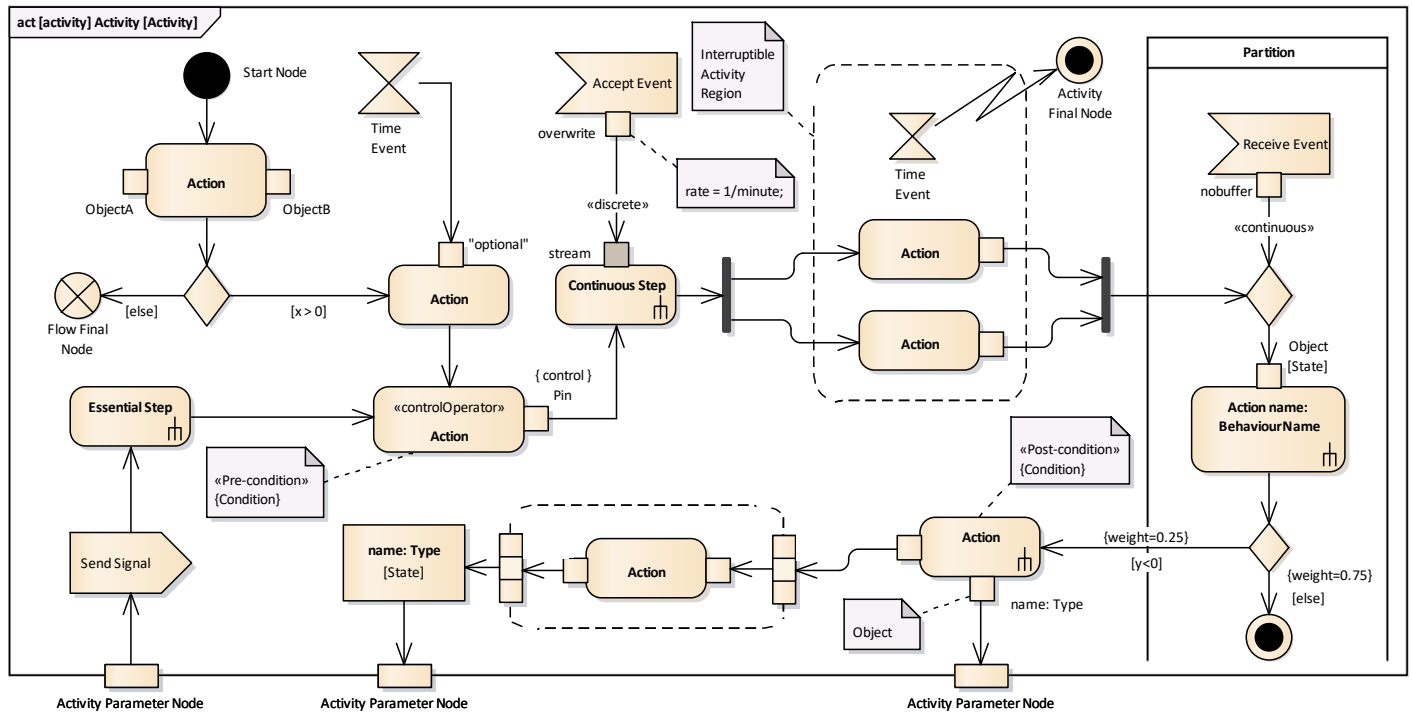

## Comments and constraints

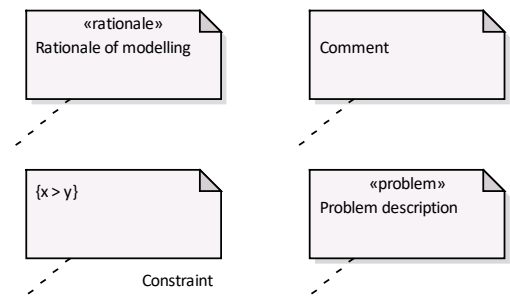

# State Machines

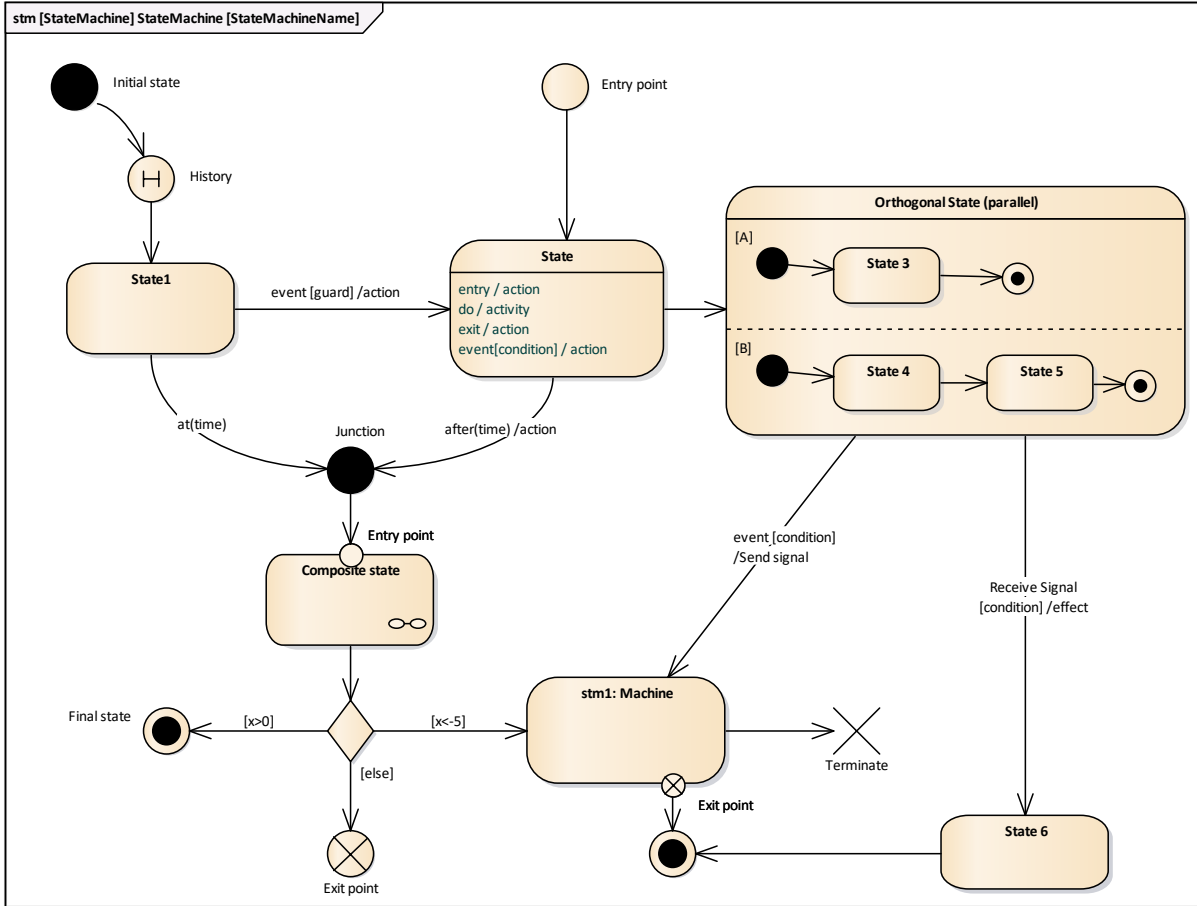

# Allocations

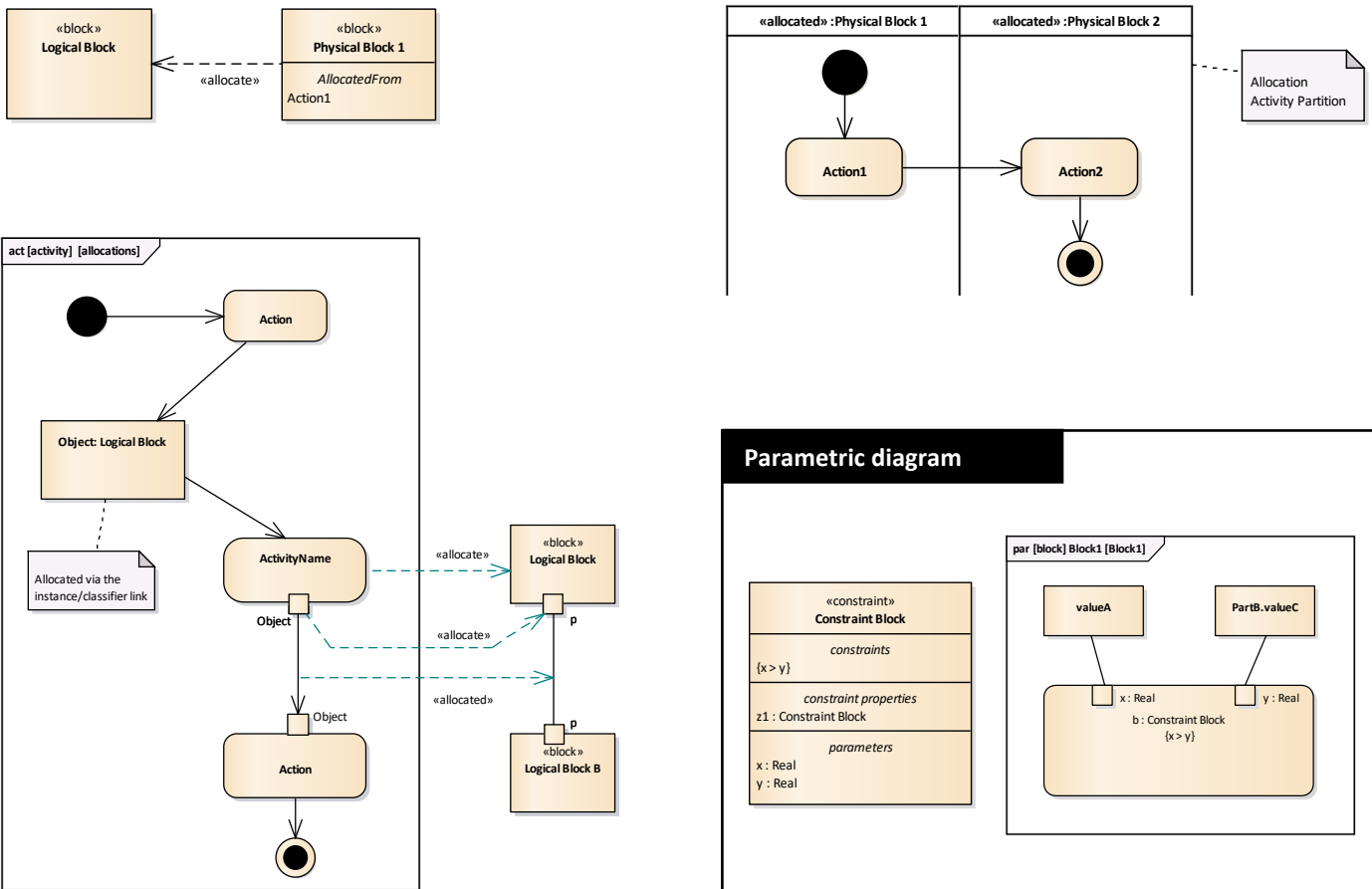

# Parametric diagram

